

Specifications

MODELS	GS™-2032		GS™-2632		GS™-3232	
	Metric	US	Metric	US	Metric	US
Working height maximum*	8.10 m	26 ft	9.92 m	32 ft	11.75 m	38 ft
A Platform height maximum	6.10 m	20 ft	7.92 m	26 ft	9.75 m	32 ft
B Platform height stowed	1.03 m	3 ft 4.5 in	1.16 m	3 ft 9.5 in	1.29 m	4 ft 2.75 in
C Platform length - outside	2.26 m	7 ft 5 in	2.26 m	7 ft 5 in	2.26 m	7 ft 5 in
extended	3.18 m	10 ft 5 in	3.18 m	10 ft 5 in	3.18 m	10 ft 5 in
Slide-out platform extension deck	0.91 m	3 ft	0.91 m	3 ft	0.91 m	3 ft
D Platform width - outside	0.81 m	2 ft 8 in	0.81 m	2 ft 8 in	0.81 m	2 ft 8 in
Guardrail height: fixed rails	0.99 m	3 ft 3 in	—	—	—	—
fold down rails	1.10 m	3 ft 7 in	1.10 m	3 ft 7 in	1.10 m	3 ft 7 in
Toeboard height	0.15 m	6 in	0.15 m	6 in	0.15 m	6 in
E Height - stowed						
fixed rails	2.03 m	6 ft 8 in	—	—	—	—
folding guardrails	2.13 m	7 ft	2.26 m	7 ft 5 in	2.43 m	8 ft
rails folded	1.75 m	5 ft 9 in	1.91 m	6 ft 3 in	2.03 m	6 ft 8 in
F Length - stowed	2.44 m	8 ft	2.44 m	8 ft	2.44 m	8 ft
Length - extended	3.33 m	10 ft 11 in	3.33 m	10 ft 11 in	3.33 m	10 ft 11 in
G Width	0.81 m	2 ft 8 in	0.81 m	2 ft 8 in	0.81 m	2 ft 8 in
H Wheelbase	1.85 m	6 ft 1 in	1.85 m	6 ft 1 in	1.85 m	6 ft 1 in
I Ground clearance - centre	0.09 m	3.5 in	0.09 m	3.5 in	0.09 m	3.5 in
J - with pothole guards deployed	0.02 m	0.75 in	0.02 m	0.75 in	0.02 m	0.75 in

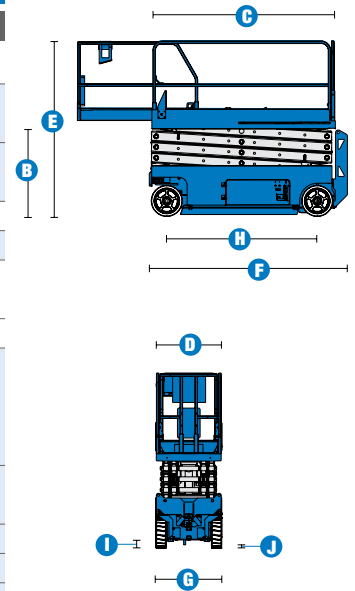

PRODUCTIVITY						
Maximum platform occupancy**						
- indoor	2	2	2	2	2	2
- outdoor	1	1	—	—	—	—
Lift capacity	363 kg	800 lbs	227 kg	500 lbs	227 kg	500 lbs
Extension deck capacity	113 kg	250 lbs	113 kg	250 lbs	113 kg	250 lbs
Drive height	full height	full height	full height	full height	6.71 m	22 ft
Drive speed - stowed	3.5 km/h	2.2 mph	3.5 km/h	2.2 mph	3.5 km/h	2.2 mph
Drive speed - raised	0.8 km/h	0.5 mph	0.8 km/h	0.5 mph	0.8 km/h	0.5 mph
Gradeability - stowed***	30%	30%	25%	25%	25%	25%
Maximum outrigger leveling: front to back	—	—	—	—	—	3°
side to side	—	—	—	—	—	5°
Turning radius - inside	zero	zero	zero	zero	zero	zero
Turning radius - outside	2.13 m	7 ft	2.13 m	7 ft	2.13 m	7 ft
Raise / lower speed	30 / 34 sec	30 / 34 sec	30 / 40 sec	30 / 40 sec	57 / 40 sec	57 / 40 sec
Controls	proportional		proportional		proportional	
Drive	dual front wheel		dual front wheel		dual front wheel	
Multiple disc brakes	dual rear wheel		dual rear wheel		dual rear wheel	
Tyres - solid non-marking	38 x 13 x 28 cm	15 x 5 x 11 in	38 x 13 x 28 cm	15 x 5 x 11 in	38 x 13 x 28 cm	15 x 5 x 11 in

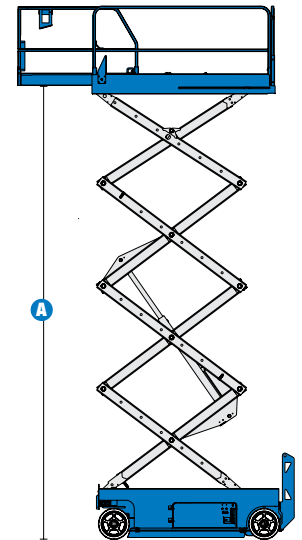

POWER						
Power source	24V DC (four 6V 225 Ah batteries)		24V DC (four 6V 225 Ah batteries)		24V DC (four 6V 225 Ah batteries)	
Hydraulic system capacity	14.2 L	3.75 gal	14.2 L	3.75 gal	14.2 L	3.75 gal

WEIGHT****						
	1,825 kg	4,024 lbs	1,956 kg	4,313 lbs	2,352 kg	5,185 lbs

STANDARDS COMPLIANCE						
	ANSI A92.6, CSA B354.2, CE Compliance, AS 1418.10					

* The metric equivalent of working height adds 2 m to platform height. U.S. adds 6 ft to platform height.
 ** CE/AUS markets: GS-2632 and GS-3232 indoor use only. GS-2032 outdoor use-one person maximum occupancy.
 *** Gradeability applies to driving on slopes. See operator's manual for details regarding slope ratings.
 **** Weight will vary depending on options and/or country standards.