

MODEL VARIATION



MAIN SPECIFICATIONS

Model		7FBE10	7FBE13	7FBE15	7FBE18	7FBE20
Load Capacity	kg	1000	1250	1500	1750	2000
Load Center	mm	500	500	500	500	500
Overall Width	A mm	1075	1075	1075	1075	1075
Turning Radius (Outside)	B mm	1365	1400	1515	1550	1675
Overhead Guard Height	C mm	1980	1980	1980	1980	1980
Length to Fork Face	D mm	1750	1755	1875	1905	2045

BATTERY AND MOTOR SPECIFICATIONS

Model			7FBE10	7FBE13	7FBE15	7FBE18	7FBE20
Voltage/Capacity (5-hour ratings)	STD	V/AH	48/280	48/280	48/390	48/390	48/390
	High	V/AH	48/365	48/365	48/565	48/565	48/645
Electric Motors	Drive	kW x Unit	4.9 x 2	4.9 x 2	4.9 x 2	4.9 x 2	4.9 x 2
	Load Handling	kW	9.2	9.2	9.2	9.2	9.2

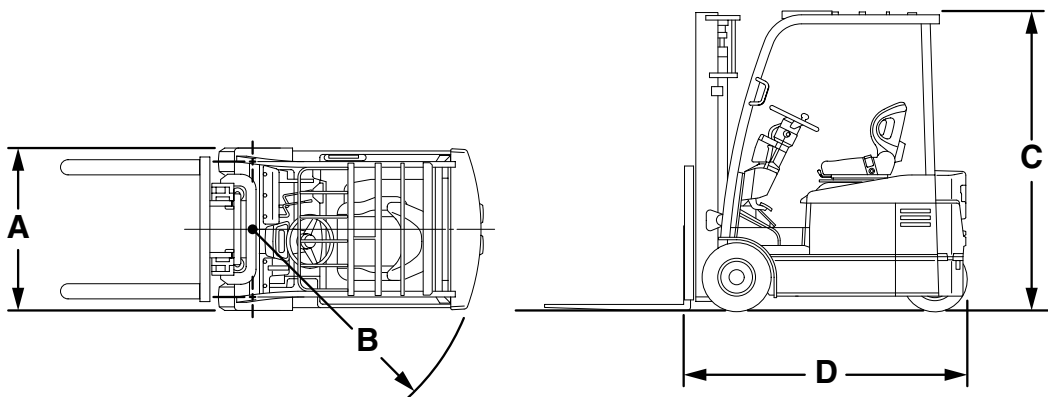

The data in this brochure is determined based on our standard testing condition.
 The performance may vary depending on the actual specification and condition of the vehicle as well as the condition of the operating area.
 Availability and specifications depend on region and are subject to change without notice.
 Due to photography and printing, color of actual vehicle may vary from this brochure. Some photos have been computer-enhanced.
 Please consult your Toyota representative for details.

All rights reserved by Toyota Industries Corporation.