

# 170 AETJ L

**Working height** .....16.90 m  
**Platform height** .....14.90 m  
**Horizontal outreach** .....9.40 m  
**Up and over clearance** .....7.15 m  
**Jib movement** .....+70° / -70°  
**Basket rotation** .....140°  
**Turret rotation** .....355°

**Platform capacity** .....200 kg/2 peoples  
**External use** .....45 km/h  
 (Maximum allowed wind speed)  
**Basket size** .....1.20 x 0.96 m

**① Width** .....1.75 m  
**② Length** .....6.84 m  
**③ Stowed length (storage)** .....5.12 m  
**④ Height** .....1.97 m  
**⑤ Stowed height (storage)** .....2.04 m

**⑥ Turning radius inside** .....1.97 m  
**⑦ Turning radius outside** .....4.30 m  
**⑧ Turning radius outside (basket)** .....5.60 m  
**⑨ Ground clearance** .....0.14 m  
**⑩ Wheel base** .....2.00 m  
**Drive speed** .....5.0 km/h  
**Working speed** .....0.6 km/h

**Gradeability** .....22%  
**Maximum slope accepted** .....5% or 3°

**Weight** .....6 910 kg

**Tires** .....0.60 x 0.19 m  
**Wheel steer** .....2 (front)  
**Wheel drive** .....2 (back)

**Batteries** .....300 Ah / 2x24 V  
**Battery charger** .....45 Ah/48 V

## Standard equipment

- Protected control basket panel
- No marking tires
- Electrical battery traction
- Negative brakes
- Lifting brackets
- Hour meter
- Warning buzzer in the basket
- 220 V predisposal
- Voltage indicator
- Safety manual pump
- Basket with mesh floor
- Bus CAN technology
- Diagnostic help integrated
- Dual electrical motors
- Rubber tires
- Integrated charger

## Options

- High capacity battery (360 Ah)
- Dual voltage charger 110 V / 230 V
- Working lights
- Electric plug in the platform with circuit breaker (230 V)
- Flashing light
- Drive alarm
- All motion alarm
- Cold conditions -20°C
- Air predisposal
- Water predisposal
- Specific painting
- Biodegradable oil
- 12" Wheels with foam filled tyres
- 12" Wheels with non marking foam filled tyres

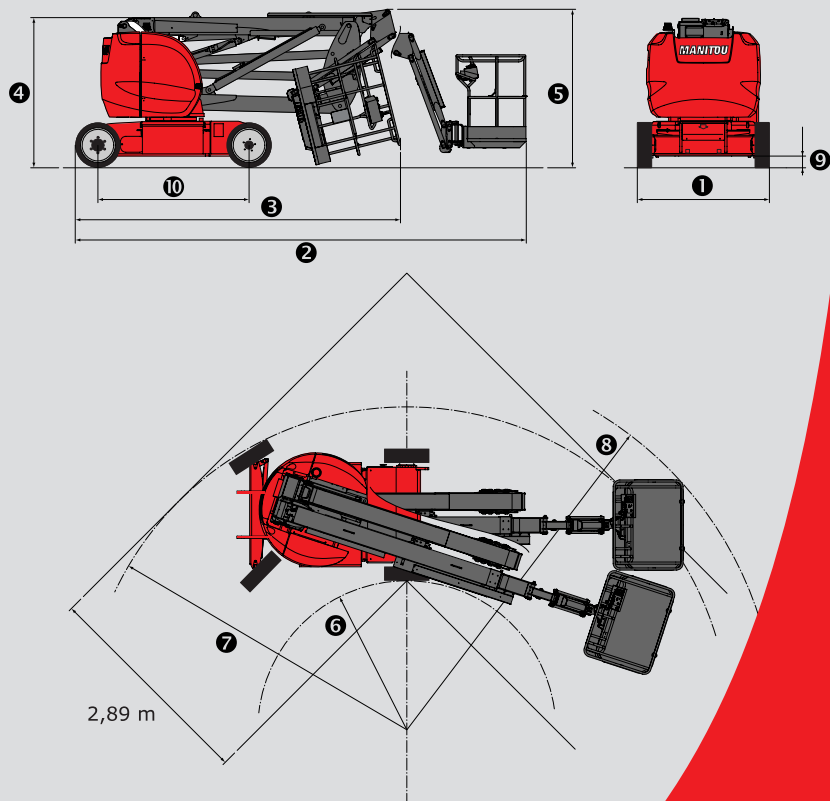
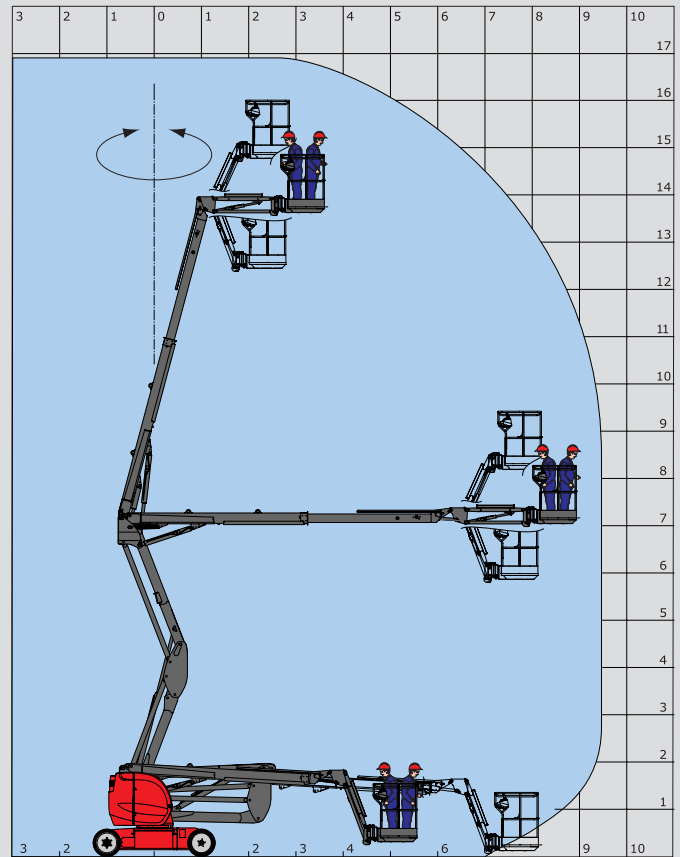

The equipment supplied with each model may differ from that described in this leaflet.  
 For more details, contact your MANITOU dealer.

